

UNIT

6

Measuring Perimeter and Area

You see geometric figures all around you.

Look at these pictures.
Identify a figure.

What would you need
to know to find the area
of that figure?

What would you need
to know to find the perimeter
of the figure?

What You'll Learn

- Use formulas to find the areas of a parallelogram, a triangle, and a trapezoid.
- Find the area and perimeter of an irregular figure.

Why It's Important

- The ability to measure is a life skill. You measure to find how much paint you need for a wall; how much fencing you need for a garden; how much material you need for drapes; and so on.





Key Words

- perimeter
- area
- parallelogram
- triangle
- trapezoid



Skills You'll Need

Perimeter and Area of a Rectangle

Perimeter is the distance around a figure.

Area is the amount of surface a figure covers.

Example 1

a) Find the perimeter of each figure.

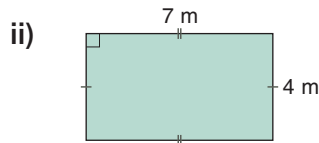
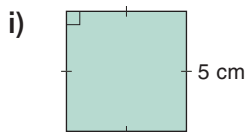

b) Find the area of each figure in part a.

Solution

a) i) The figure is a square.

The perimeter of a square is: $P = 4s$

Substitute $s = 5$.

$$P = 4 \times 5$$

$$= 20$$

The perimeter is 20 cm.

ii) The figure is a rectangle.

The perimeter of a rectangle is: $P = 2(b + h)$

Substitute $b = 7$ and $h = 4$.

$$P = 2(7 + 4)$$

$$= 2 \times 11$$

$$= 22$$

The perimeter is 22 m.

b) i) The area of a square is: $A = s^2$

Substitute $s = 5$.

$$A = 5^2$$

$$= 5 \times 5$$

$$= 25$$

The area is 25 cm².

ii) The area of a rectangle is: $A = bh$

Substitute $b = 7$ and $h = 4$.

$$A = 7 \times 4$$

$$= 28$$

The area is 28 m².

✓ Check

1. Find the perimeter and area of each figure.

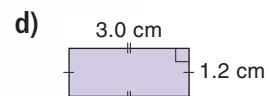
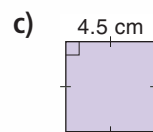
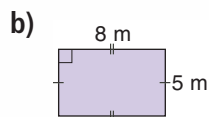
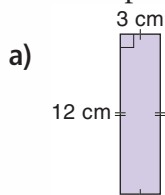

Focus Use a formula to find the area of a parallelogram.

This is a **parallelogram**.
How would you describe it?

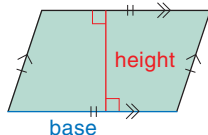

Here is the same parallelogram.
Any side of the parallelogram is a base.
The height is perpendicular to the base.

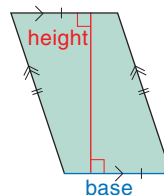

Explore

Work with a partner.

You will need a tangram and grid paper.

- One tan is a parallelogram. Find its area.
- Make another parallelogram by combining tans. Find the area of the parallelogram.
- Continue to combine tans to make different parallelograms. Find the area of each parallelogram you make.
- Record your work. Draw each parallelogram on grid paper.
- Use variables. Write a formula to find the area of a parallelogram.



Reflect & Share

How did you find the area of each parallelogram?

Which different strategies did you use?

Which strategy helped you write the formula for the area?

Connect

Recall that both a rectangle and a square are parallelograms.

Any parallelogram that is not a rectangle can be “cut” and rearranged to form a rectangle.

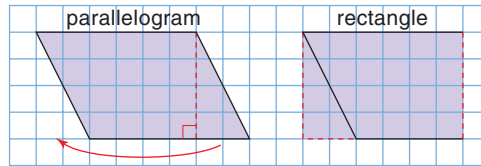

The parallelogram and the rectangle have the same area.
The area of a parallelogram is equal to the area of a rectangle with the same height and base.

To find the area of a parallelogram, multiply the base by the height.

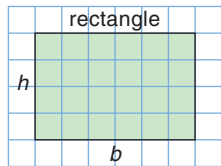

Area of rectangle:
 $A = bh$

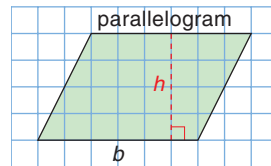

Area of parallelogram:
 $A = bh$

b represents the base.
 h represents the height.

Example

Calculate the area of each parallelogram.

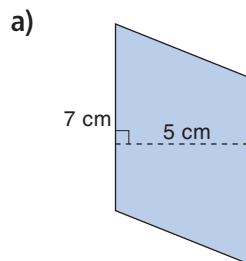

a) $A = bh$
Substitute $b = 7$ and $h = 5$.
 $A = 7 \times 5$
 $= 35$
The area of the parallelogram is 35 cm^2 .

b) The height can be drawn outside the parallelogram.

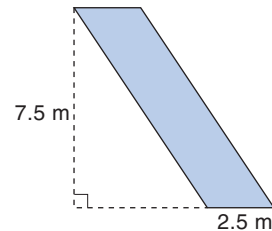

b) $A = bh$
Substitute $b = 2.5$ and $h = 7.5$.
 $A = 2.5 \times 7.5$
 $= 18.75$
The area of the parallelogram is 18.75 m^2 .

Practice

Recall that you can use a protractor to draw the height perpendicular to the base.

The base of a parallelogram is not always horizontal.

1. Identify one base and height of each parallelogram.

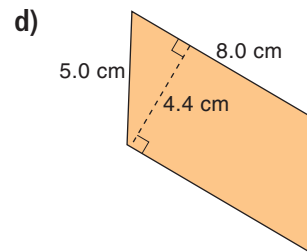
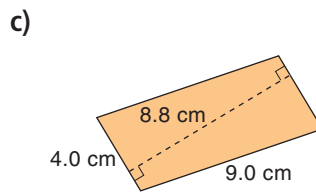
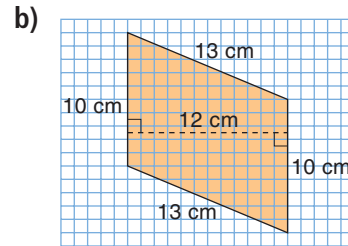
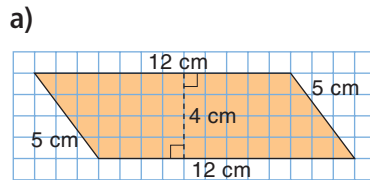

2. Find the area of each parallelogram in question 1.

3. a) On 1-cm grid paper, draw 3 different parallelograms with each base and height.

i) base: 3 cm; height: 5 cm ii) base: 3.5 cm; height: 7.0 cm

- b) Find the area of each parallelogram you drew in part a. What do you notice?

4. On 1-cm grid paper, draw as many different parallelograms as you can with each area.

a) 10 cm^2 b) 18 cm^2 c) 28 cm^2

5. **Assessment Focus** Use 1-cm grid paper.

Draw a parallelogram, which is not a rectangle, with base 6 cm and height 4 cm.

- a) What is the area of the parallelogram?
 b) Change the base to draw a parallelogram with twice the area. What is the base?
 c) Change the height to draw a parallelogram with twice the area. What is the height?
 d) Change the base and height to draw a parallelogram with twice the area.

How many different pairs of base and height can you find? Show your work.

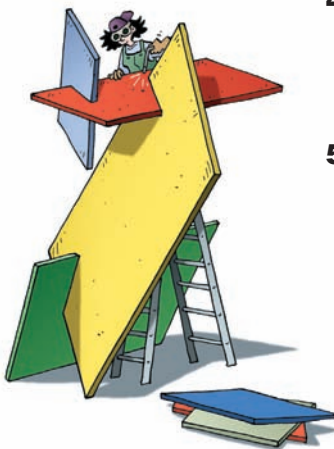

Mental Math

It is Wednesday, January 14.
Kim and Sun-Yi are working together.

Kim works every Wednesday.
Sun-Yi works every 5th day.

When will Kim and Sun-Yi next work together?



6. The area of each parallelogram is given. Find each unknown measure.

a) the height

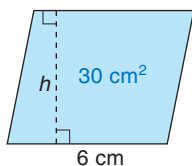

b) the base

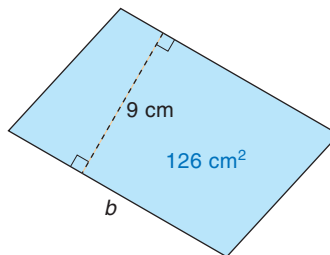

c) the height

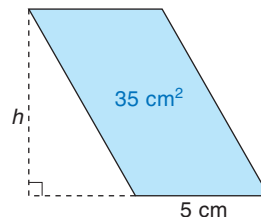

7. Use 1-cm grid paper.

Draw a rectangle with the same area as each parallelogram in question 6.

How many different ways can you do this?

8. Sasha is buying paint for a design on a wall.

Here is part of the design.

Sasha says figure B will need more paint than figure A.

Do you agree? Explain.

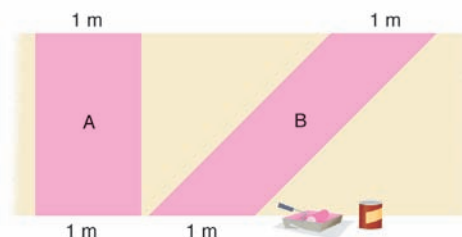

9. You will need 1-cm grid paper, ruler, and tracing paper. Draw a parallelogram with base 10 cm and height 6 cm. Draw a diagonal to make two triangles.

a) What do you notice about the two triangles?

How can you check your observation?

b) What is the area of the parallelogram?

c) What is the area of each triangle? How do you know?

10. A restaurant owner built a patio in front of his store to attract more customers.

a) What is the area of the patio?

b) What is the total area of the patio and gardens?

c) How can you find the area of the gardens?

Show your work.

Take It Further

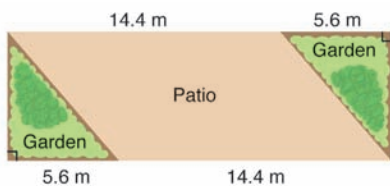

Reflect

What do you need to know to find the area of a parallelogram?
Use an example to explain.

Explore

Work with a partner.

You will need a ruler and 1-cm grid paper.

Draw each triangle below on 1-cm grid paper.

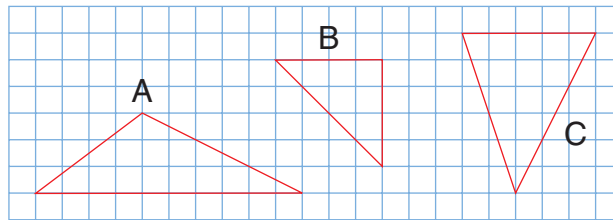

- How many different ways can you find the area of each triangle? What strategies did you use?
- Use what you know about parallelograms. Find the area of each triangle.
- Use variables. Write a formula to find the area of a triangle.

Reflect & Share

How did you use a parallelogram to find the area of a triangle?

Compare your formula with that of another pair of classmates.

If the formulas are different, can both of them be used to find the area of a triangle? Explain.

Connect

When we draw a diagonal in a parallelogram, we make 2 congruent triangles.

Congruent triangles have the same area.

So, the area of one triangle is $\frac{1}{2}$ the area of the parallelogram.

To find the area of this triangle:

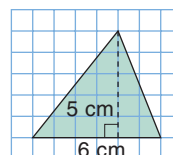
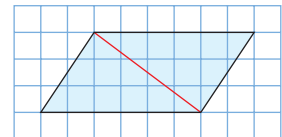

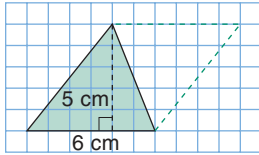

Complete a parallelogram on one side of the triangle.

The area of the parallelogram is:

$$A = \text{base} \times \text{height, or } A = bh$$

$$\text{So, } A = 6 \times 5$$

$$= 30$$

The area of the parallelogram is 30 cm^2 .

So, the area of the triangle is: $\frac{1}{2}$ of $30 \text{ cm}^2 = 15 \text{ cm}^2$

We can write a formula for the area of a triangle.

$$A = \frac{1}{2} \text{ base} \times \text{height}$$

$$A = \frac{1}{2} bh$$

$$\text{or } A = bh \div 2$$

$$\text{or } A = \frac{bh}{2}$$

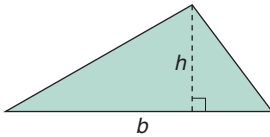

Example

Find the area of each triangle.

For an obtuse triangle, the height might be drawn outside the triangle.

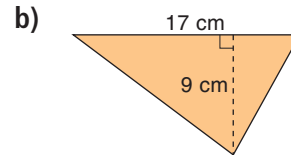
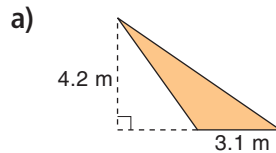

Solution

a) $A = \frac{bh}{2}$

Substitute $b = 3.1$

and $h = 4.2$.

$$A = \frac{3.1 \times 4.2}{2}$$

$$A = 6.51$$

The area is 6.51 m^2 .

b) $A = \frac{bh}{2}$

Substitute $b = 17$ and $h = 9$.

$$A = \frac{17 \times 9}{2}$$

$$A = \frac{153}{2}$$

$$= 76.5$$

The area is 76.5 cm^2 .

Practice

1. Identify one base and height of each triangle.

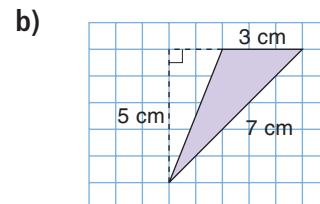
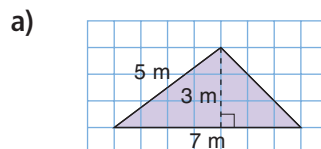

In a right triangle, one base and height are two sides of the triangle.

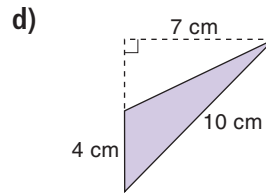
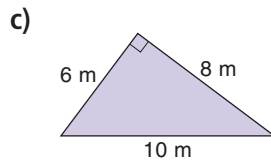

2. Find the area of each triangle in question 1.
3. a) On 1-cm grid paper, draw 3 different triangles with each base and height.
 - i) base: 4 cm; height: 3 cm
 - ii) base: 7.5 cm; height: 6.5 cm
 b) Find the area of each triangle you drew in part a. What do you notice?
4. On 1-cm grid paper, draw two different triangles with each area.
 - a) 16 cm^2
 - b) 8 cm^2
 - c) 10 cm^2
5. Use 1-cm grid paper.
 - a) Draw a triangle with area 12 cm^2 .
 - b) Investigate the different ways you can draw a triangle that has:
 - i) double the area
 - ii) one-half the area
 Write a report of your findings.
6. Use 1-cm grid paper.
 - a) Draw different triangles with base 4 cm and height 6 cm.
 - b) Find the area of each triangle you draw.
 - c) Measure the side lengths of each triangle you draw. How do you know all the triangles are different?

Calculator Skills

Which is the best deal?
How do you know?
250 g cheese for \$2.99
400 g cheese for \$4.99
600 g cheese for \$6.79

7. The area of each triangle is given. Find each unknown measure.
 - a) the base
 - b) the height

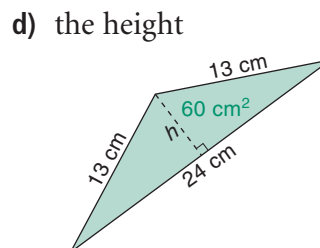
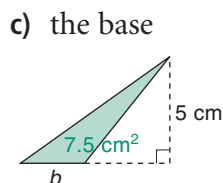
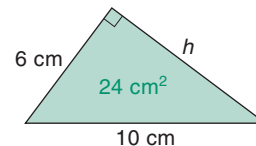
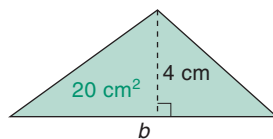



Math Link

Your World

You use rulers and protractors to measure in the classroom.

Which measuring instruments do you have at home?

What do these instruments measure?

List all the instruments you can find.

Give an example of what each one measures.

8. When you know the area of a triangle, and its base, how can you find its height? Use an example to explain.

9. **Assessment Focus** The owner of a house paints this attic wall. There is a small rectangular window in the wall.

One litre of paint covers 6.5 m^2 .

a) What is the area that is to be painted?

b) The paint comes in 1-L cans.

How many cans does the owner need?

Explain your answer.

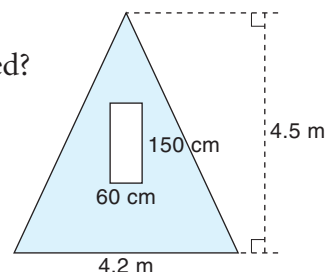

Take It Further

10. A local park has a pavilion to provide shelter. The pavilion has a roof the shape of a rectangular pyramid.

a) What is the total area of all four parts of the roof?

b) One sheet of plywood is

240 cm by 120 cm.

It costs \$24.95.

What is the least number of sheets of plywood

needed to cover the roof?

What is the cost?

Explain how you got your answer.

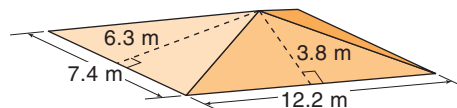

Reflect

A triangle and a parallelogram have the same base and height.

How are the areas of the triangle and parallelogram related?

Use an example to explain.

Mid-Unit Review

LESSON

- 6.1 1.** Find the perimeter and area of each figure.

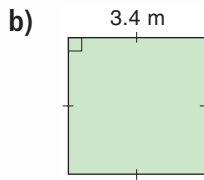
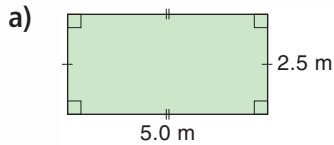

- 2.** Find the area of each parallelogram.

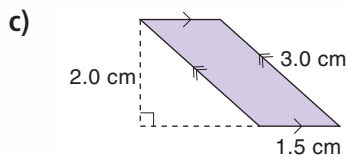
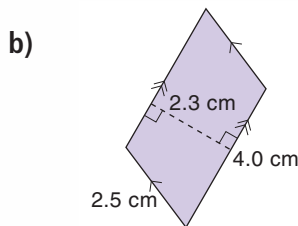
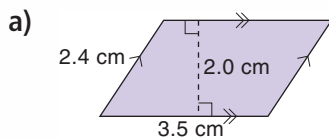

- 3.** A parallelogram has height 45 cm and base 60 cm.
- Find its area.
 - What is the base and height of a parallelogram with twice the area?
 - What is the base and height of a parallelogram with one-half the area?

- 6.2 4.** Find the area of each triangle.

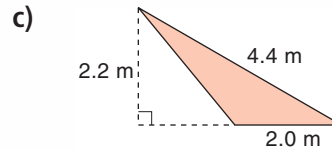
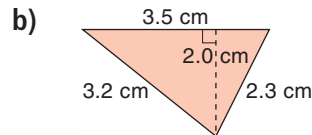
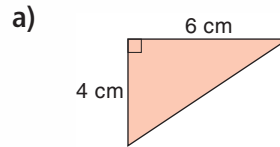

- 5.** Po Ling is planning to pour a concrete patio beside her house. It has the shape of a triangle. The contractor charges \$125.00 for each square metre of concrete poured.

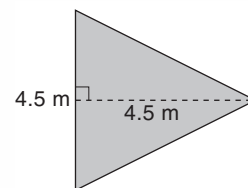

What will the contractor charge for the concrete?



Focus Use a formula to find the area of a trapezoid.

This is a **trapezoid**.

How would you describe it?

Recall that a rectangle, a square, and a parallelogram are trapezoids, too.

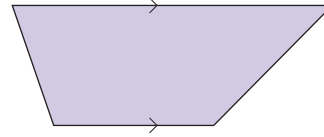

Explore

Work with a partner.

You will need scissors.

Your teacher will give you a copy of the figures below.

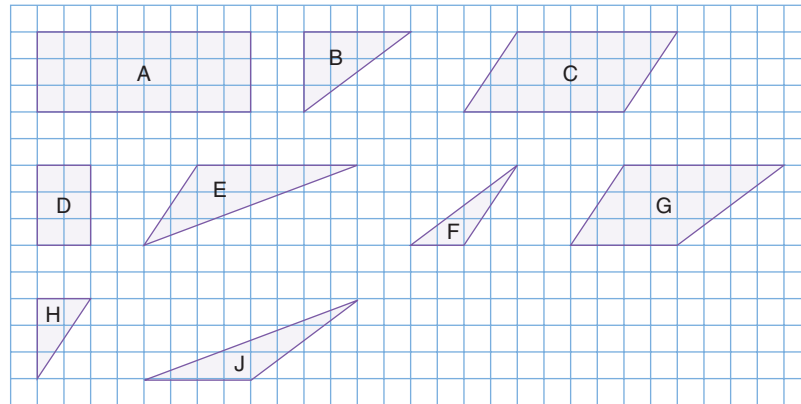

- Find the area of each figure.
- Cut out the figures.
- Identify the trapezoid that is not a parallelogram.
- How many different ways can you use the figures to find the area of the trapezoid?
- For each way you find, write a formula in words for the area of a trapezoid.
- Find the perimeter of the trapezoid.

Reflect & Share

How did you use what you know about the areas of a triangle, a rectangle, and a parallelogram to find the area of a trapezoid?

We can find the area of a trapezoid by dividing it into other figures. Here are 3 ways to find the area of this trapezoid.

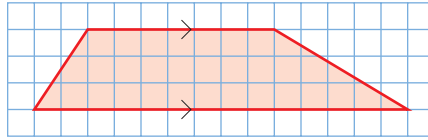

- Make 2 triangles and a rectangle.

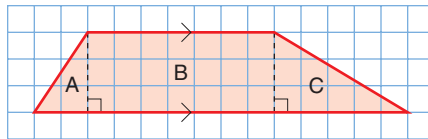

$$\text{Area of trapezoid} = \text{area of triangle A} + \text{area of rectangle B} + \text{area of triangle C}$$

- Make 1 triangle and a parallelogram.

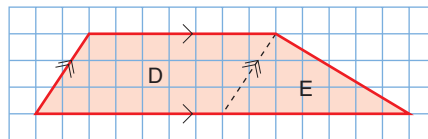

$$\text{Area of trapezoid} = \text{area of parallelogram D} + \text{area of triangle E}$$

- Make 2 triangles.

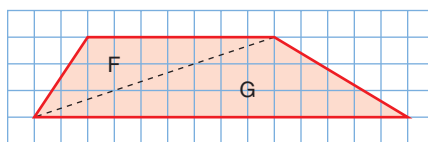

$$\text{Area of trapezoid} = \text{area of triangle F} + \text{area of triangle G}$$

Example

- Estimate the area of this trapezoid.
- Calculate the area to check your estimate.

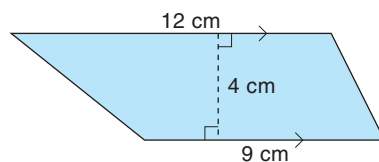

Solution

- a) Sketch a rectangle with width 4 cm and length between 9 cm and 12 cm, maybe 10 cm. The area of the rectangle is an estimate of the area of the trapezoid.

$$\begin{aligned}\text{Area of rectangle} &= 10 \times 4 \\ &= 40\end{aligned}$$

The area of the trapezoid is about 40 cm².

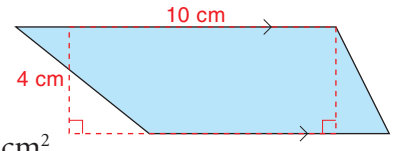

- b) Divide the trapezoid into 2 triangles.

$$\text{Area of triangle A} = \frac{bh}{2}$$

Substitute $b = 12$ and $h = 4$.

$$\begin{aligned}\text{So, area} &= \frac{12 \times 4}{2} \\ &= 24\end{aligned}$$

$$\text{Area of triangle B} = \frac{bh}{2}$$

Substitute $b = 9$ and $h = 4$.

$$\begin{aligned}\text{So, area} &= \frac{9 \times 4}{2} \\ &= 18\end{aligned}$$

Area of trapezoid = area of triangle A + area of triangle B

$$= 24 + 18$$

$$= 42$$

The area of the trapezoid is 42 cm².

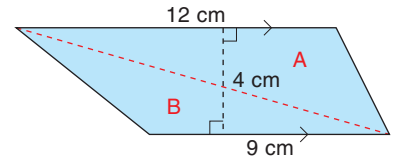

Practice

1. Find the area of each trapezoid by dividing it into 2 triangles.

a)

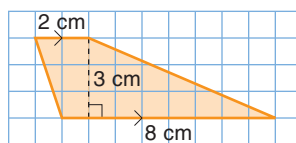

b)

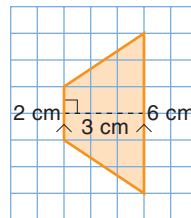

c)

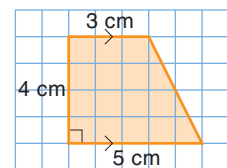

2. Find the area of each trapezoid by dividing it into 1 or 2 triangles and a rectangle.

a)

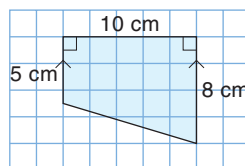

b)

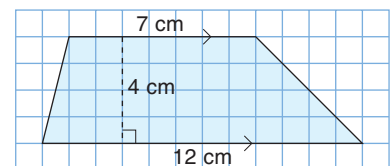

Calculator Skills

Predict each product.

Check your prediction.

What patterns do you see in the answers?

- 9×9
- 99×99
- 999×999
- 9999×9999

Use the pattern to predict the product of $99\,999 \times 99\,999$.

3. Find the area of each trapezoid.

a)

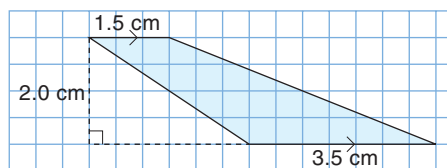

b)

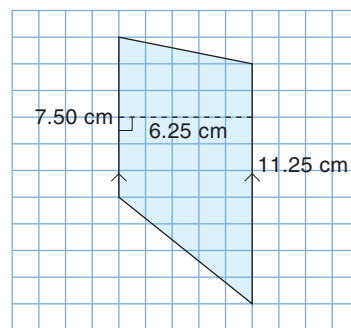

4. Find the area and perimeter of each trapezoid.

a)

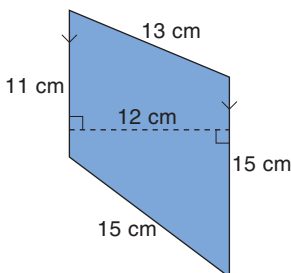

b)

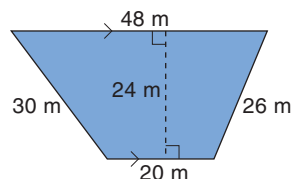

5. a) Estimate the area of each trapezoid.

Check your answer by calculating the area.

i)

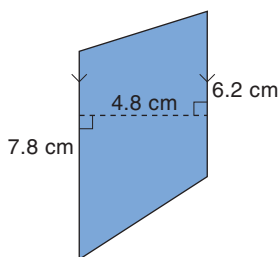

ii)

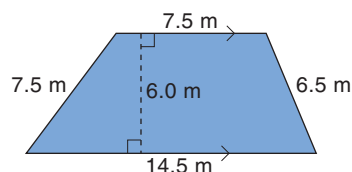

b) Can you find the perimeter of each trapezoid in part a? Explain.

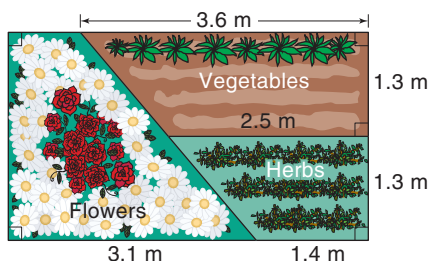

6. a) What is the area of each part of this garden?

b) Find the area of the whole garden two different ways.

7. Suppose you have a piece of string, 4 pushpins, a ruler, and grid paper.

a) Describe how to make a trapezoid with perimeter 20 cm.

Use your strategy to make the trapezoid.

b) Draw the trapezoid on grid paper.

c) Find the approximate area of the trapezoid.

- 8. Assessment Focus** Two congruent trapezoids join to form a parallelogram.

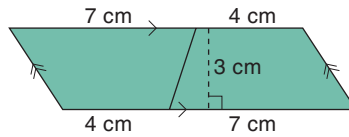

- How can you use the area of the parallelogram to find the area of each trapezoid?
- Use grid paper. Draw a trapezoid. Use the area of a parallelogram to find the area of your trapezoid. Show your work.

Take It Further

- 9.** A patio is made with congruent brick tiles.

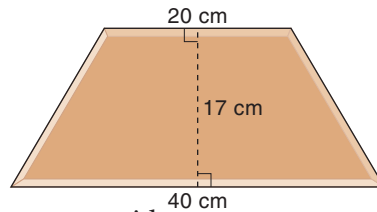

Each tile is a trapezoid.

- What is the area of the top face of each tile?
- Use red Pattern Blocks on triangular grid paper. Sketch a patio that uses these trapezoid tiles. How many tiles are in your patio?
- What is the area of your patio?
- When a patio is built, there is a 3-mm space between tiles for the grout. Would your completed patio be larger or smaller than the area you calculated in part c? Explain. How much larger or smaller would it be?



- 10.** Use any of the methods you know to find the area of a trapezoid. Use variables. Write a formula for the area of a trapezoid.

Reflect

How can you use the strategies for finding the area of a trapezoid to find the areas of a square, rectangle, and parallelogram? Use examples to explain.

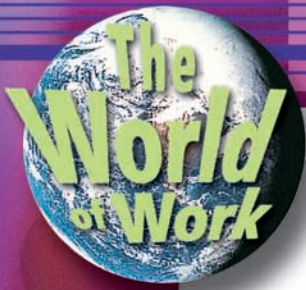

Measuring for Construction

Before construction begins on a shopping mall, the site is precisely measured in different ways for different reasons. Measuring does not stop once construction begins. Initial measurements are checked and rechecked because estimates and plans sometimes change as the project continues.

The first “measurers” on the site are members of a survey team. The first thing they do is to verify the perimeter and area with an older, existing plan. In some cases, the last survey for the site might have been carried out 200 years before.

Most surveyors today have new, technology-based surveying tools. However, the team might use a transit (an angle-measuring device based on a telescope) and stadia (a graduated measuring rod). These measuring devices have been in use since the early 19th century. The survey team may have aerial or satellite photographs, EDM (Electronic Distance Measuring) equipment based on microwaves or lasers, or GPS (Global Positioning System) equipment.



A construction project requires the services of many different suppliers and contractors. One company provides security fencing around the site. Another company lays asphalt for the roads and parking lots. A third company installs the flooring and carpets inside the mall. Some people work from the architect’s blueprints to calculate how much to charge for their materials and labour. Other people will send an estimator to do her own measuring. Estimators use a variety of measuring tools: tape measure, trundle wheel, hand-held EDM, and so on. The estimators have to know how to use the measurements they collect.

Recently, a company introduced a digital measuring device. This device is wheeled around the perimeter of the region to calculate the area of the region. Why might this seem to be an impossible calculation? Can you explain how it might work?

Interpreting a Problem

Problem

How many different trapezoids can you draw with area 24 cm^2 ?

Interpret the problem

A trapezoid has at least 1 pair of parallel sides.

A trapezoid could have 2 pairs of parallel sides.

It would then be a rectangle or a parallelogram.

Solve the problem

Solution 1

To draw a rectangle with area 24 cm^2 , find two factors of 24.

The factors in each pair are the base and the height of the rectangle:

1×24 , 2×12 , 3×8 , 4×6

Each of these rectangles has area 24 cm^2 .

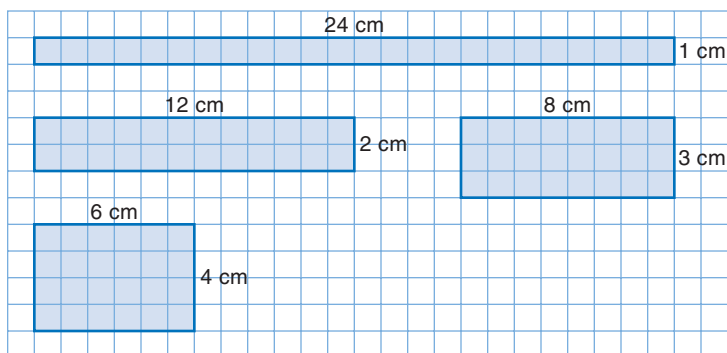

Solution 2

To draw a parallelogram with area 24 cm^2 ,

use the factors in *Solution 1*.

The factors in each pair are the base and the height of the parallelogram.

Each of these parallelograms has area 24 cm^2 .

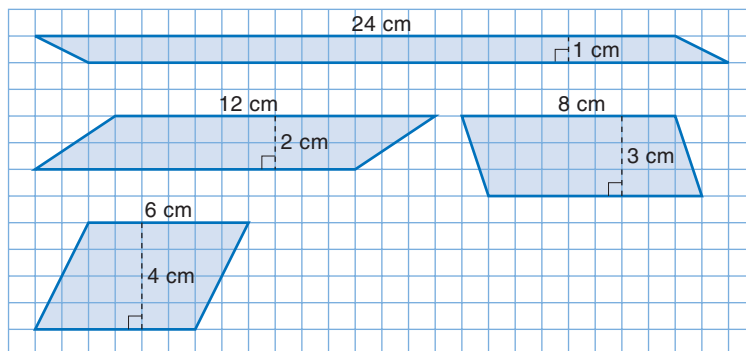

Solution 3

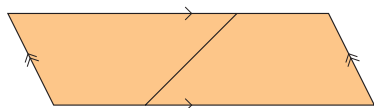

To draw a trapezoid (that is not a parallelogram) with area 24 cm^2 :

Two congruent trapezoids join to form a parallelogram. If each trapezoid has area 24 cm^2 , then the parallelogram has area 48 cm^2 .

Work backward.

Draw a parallelogram with area 48 cm^2 .

Divide it into 2 congruent trapezoids.

A parallelogram with area 48 cm^2 can have base 12 cm and height 4 cm .

Choose a length for one base of the trapezoid, less than 12 cm .

Choose 10 cm . Mark a point on the top side of the parallelogram 10 cm from the left vertex.

Mark a point on the bottom side of the parallelogram 10 cm from the right vertex.

Join these points to form two congruent trapezoids. So, one trapezoid with area 24 cm^2 looks like this:

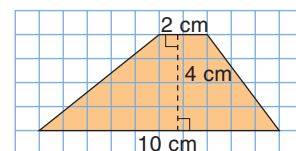
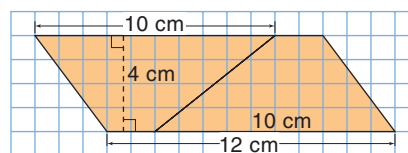

Look back

- What if we had chosen a parallelogram with base 8 cm and height 4 cm ?
What could the trapezoid look like?
- What if we had chosen 5 cm for one base of the trapezoid?
What would the trapezoid look like?



Problems

1. Draw 3 different trapezoids with area 30 cm^2 .
2. Think of other methods to find the area of a trapezoid.
Use a different method to draw a trapezoid with area 20 cm^2 .

Reflect

Choose an area for a trapezoid. Explain how to draw a trapezoid with that area. Include a diagram.

6.4

Measuring Irregular Figures

Focus Find the area and perimeter of an irregular figure.

In *Section 6.3*, you calculated the area of a trapezoid by dividing it into other figures.

You can use a similar strategy to find the areas of other irregular figures.



Explore

Work with a partner.
A garden in a backyard has this plan.

How many different ways can you find the area of the garden?
What is its perimeter?

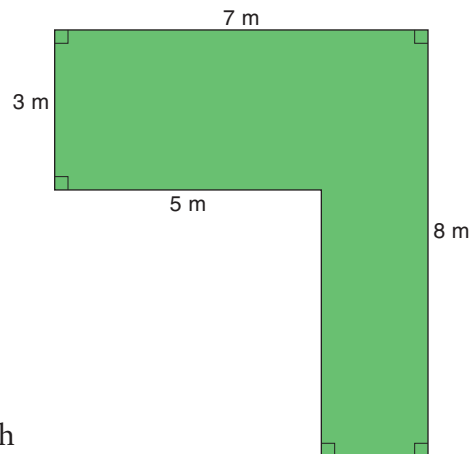

Reflect & Share

Compare your strategies with those of another pair of students.
What other strategies could you have used?

Connect

Here are two ways to find the area of this irregular figure.

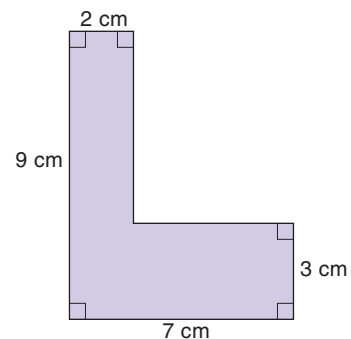

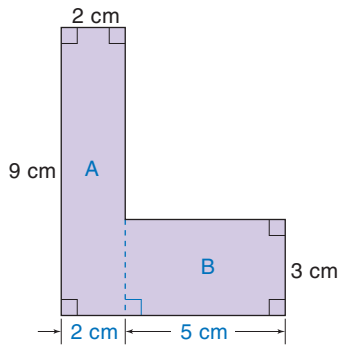

- Divide the figure into smaller figures whose areas you can find.
 Rectangle A has length 9 cm and width 2 cm.
 Area of rectangle A: $9 \text{ cm} \times 2 \text{ cm} = 18 \text{ cm}^2$
 Since the width of rectangle A is 2 cm,
 the length of rectangle B is: $7 \text{ cm} - 2 \text{ cm} = 5 \text{ cm}$
 Area of rectangle B: $3 \text{ cm} \times 5 \text{ cm} = 15 \text{ cm}^2$
 So, the area of the figure is: $18 \text{ cm}^2 + 15 \text{ cm}^2 = 33 \text{ cm}^2$

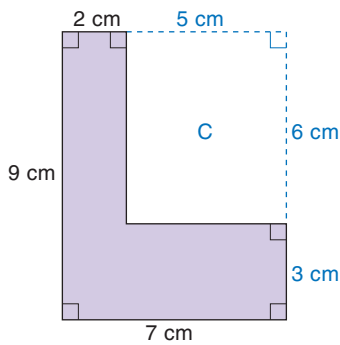

- Draw a rectangle around the figure.
 The area of the large rectangle is: $9 \text{ cm} \times 7 \text{ cm} = 63 \text{ cm}^2$
 Figure C is a rectangle.
 Its width is: $7 \text{ cm} - 2 \text{ cm} = 5 \text{ cm}$
 Its length is: $9 \text{ cm} - 3 \text{ cm} = 6 \text{ cm}$
 Area of rectangle C: $5 \text{ cm} \times 6 \text{ cm} = 30 \text{ cm}^2$
 So, the area of the figure is: $63 \text{ cm}^2 - 30 \text{ cm}^2 = 33 \text{ cm}^2$

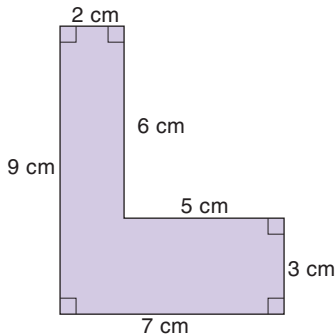

- To find the perimeter of the figure, add the side lengths.
 Perimeter
 $= 2 \text{ cm} + 6 \text{ cm} + 5 \text{ cm} + 3 \text{ cm} + 7 \text{ cm} + 9 \text{ cm}$
 $= 32 \text{ cm}$
 The perimeter is 32 cm.

Example

Here is a plan of the back wall of a barn.

- What is the area of the wall?
- One can of paint covers 40 m^2 . How many cans are needed to paint this wall?

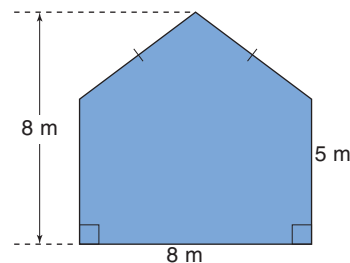

Solution

The wall is a rectangle with an isosceles triangle above it.

a) For the triangle:

The base, b , is 8 m.

The height, h , is $8 \text{ m} - 5 \text{ m} = 3 \text{ m}$.

$$\text{Area} = \frac{bh}{2}$$

Substitute $b = 8$ and $h = 3$.

$$\begin{aligned} \text{Area} &= \frac{8 \times 3}{2} \\ &= 12 \end{aligned}$$

For the rectangle:

$$\text{Area} = bh$$

Substitute $b = 8$ and $h = 5$.

$$\begin{aligned} \text{Area} &= 8 \times 5 \\ &= 40 \end{aligned}$$

$$\begin{aligned} \text{Area of wall} &= 40 \text{ m}^2 + 12 \text{ m}^2 \\ &= 52 \text{ m}^2 \end{aligned}$$

The area of the wall is 52 m^2 .

b) The area of the wall is 52 m^2 .

One can of paint covers 40 m^2 .

One can is not enough.

Two cans of paint are needed.

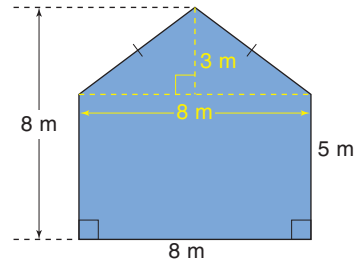

Practice

1. A living room in a home has the shape, below left.

What is the area of the living room?

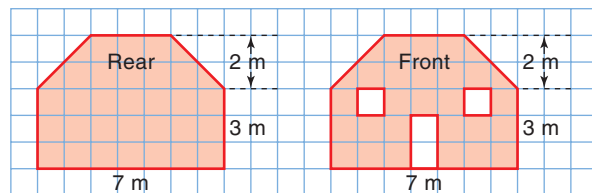
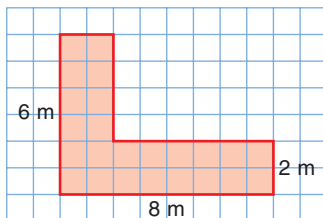

2. The rear and front walls of a shed are shown, above middle and right.

a) Find the area of the rear wall.

b) Find the area of the front wall, excluding the windows and door.

Number Strategies

Which is the next number in each pattern?

Write each pattern rule.

3, 9, 27, 81, ____

12, 14, 18, 26, ____

52, 28, 16, 10, ____

5, 14, 41, 122, ____



Reflect

3. The diagram shows the basement floor of a home.
- Estimate the area and perimeter of the floor.

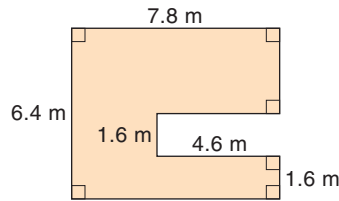

- Calculate the area and perimeter of the floor.
 - Compare your estimates with your calculations. Was your estimate reasonable? Explain.
4. This diagram shows a plan of a parking lot.
- Estimate the area and perimeter of the lot.
 - Calculate the area and perimeter of the lot.
 - How could you use the grid to verify your answers?

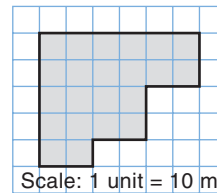

5. A backyard is a rectangle 15 m long by 10 m wide. In one corner, there is a rectangular garden 5 m by 3 m.
- Use grid paper. Draw a diagram of the backyard.
 - Calculate the area of the backyard, excluding the garden.
 - What if the garden was in a different place in the yard? Would the answer to part b be different? Explain.
6. **Assessment Focus** An L-shaped swimming pool has area 30 m^2 . Each rectangular arm has width 3 m.
- Use grid paper. Draw 3 different pools.
 - Find the perimeter of each pool you drew. What do you notice about the perimeters?
 - What if the width of each arm was 5 m? What effect does this have? Explain.

There are different ways to find the area of an irregular figure. Which way do you prefer to use? Use an example to explain your reasoning.

Game

Trapezoid Challenge

HOW TO PLAY THE GAME:

1. Roll 3 number cubes to get the height and lengths of the 2 parallel sides of a trapezoid.

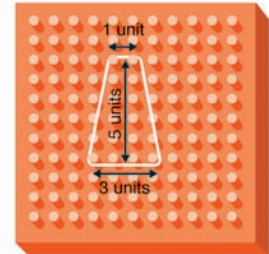

2. Use the geoboard to make a trapezoid with those dimensions.
Choose which number represents which dimension.

YOU WILL NEED

11 by 11 geoboard;
geobands; 3 number cubes
labelled 1 to 6; dot paper

NUMBER OF PLAYERS

3 or 4

GOAL OF THE GAME

To get 50 points



3. The area of the trapezoid is your score for the round.
4. Take turns.
The winner is the first person to reach 50 points.

What strategies did you use to try to win?
Does it matter which of the 3 numbers you use for the height? Explain.

Variation: Record each trapezoid on grid paper. No two trapezoids can be the same. If you cannot create a different trapezoid, you forfeit your turn.

What Do I Need to Know?

✓ The *perimeter* of a figure is found by adding the lengths of its sides.

✓ **Area of a Parallelogram**

$$A = bh$$

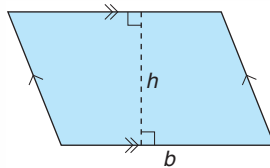

✓ **Area of a Triangle**

$$A = \frac{bh}{2}$$

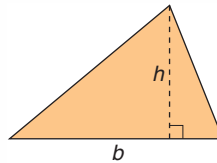

✓ **Area of a Trapezoid**

Divide the trapezoid into:

- Two triangles
- A parallelogram and a triangle
- A rectangle and 2 triangles

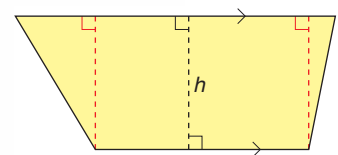
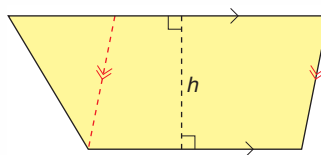
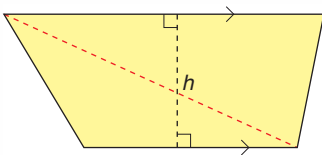

✓ **Area of an Irregular Figure**

- Divide the figure into figures whose area you can find, then add the areas.
- Or, draw a rectangle around the figure; subtract the areas of the newly formed figures from the area of the rectangle.

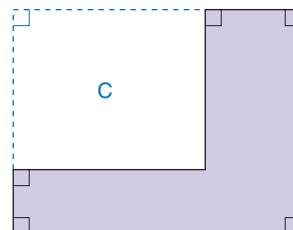
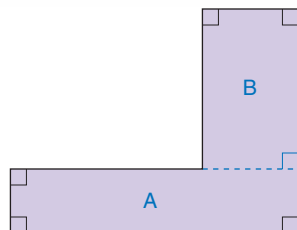

LESSON

6.1 1. Find the area of each figure.

6.2 Explain your strategy.

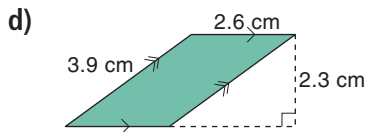
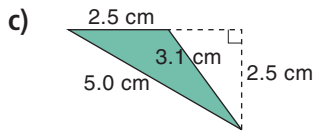
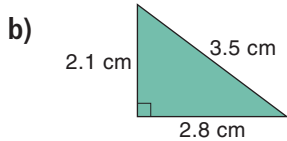
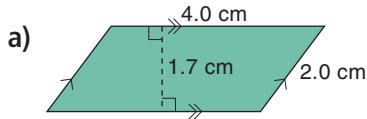

6.3 2. Estimate the area of each trapezoid. Then, calculate the area to check if your estimate was reasonable.

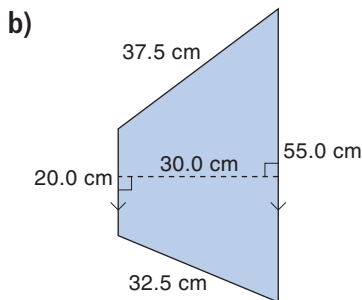
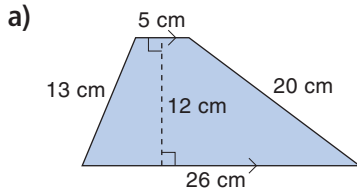

3. Estimate the perimeter of each trapezoid in question 2. Then, calculate the perimeter to check.

4. The area of this trapezoid is approximately 150 cm^2 .

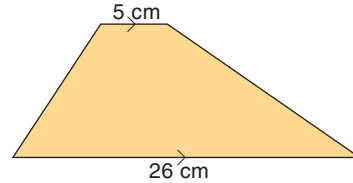

Estimate its height. Show your work.

6.4 5. Find the perimeter and area of each figure.

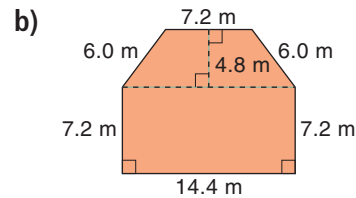
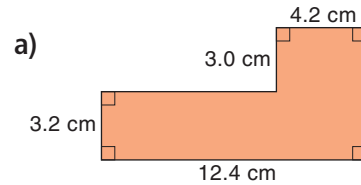

6. A school playground has a paved surface and a grass surface.

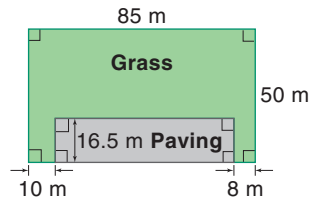

- What is the area of the paved surface?
- Fencing costs $\$35.50/\text{m}$. How much would it cost to fence the grass area?

Practice Test

1. Find the area and perimeter of each figure.

Explain your strategies.

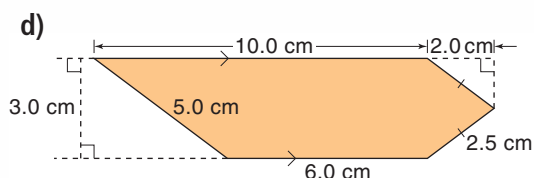
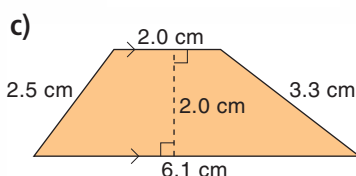
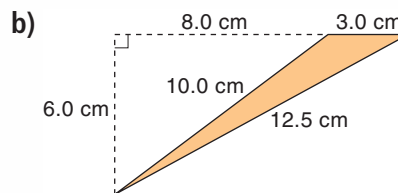
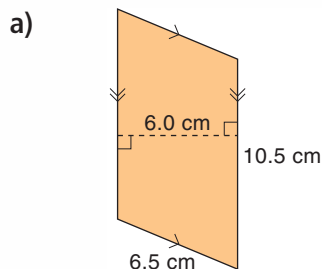

2. How does the area of a triangle change in each case?

- Its height is doubled.
- Its base is halved.
- Its height is doubled and its base is halved.

Explain how you know.

3. Use 1-cm grid paper.

Draw an irregular figure with area 64 cm^2 .

Label all the dimensions of the figure.

Find the perimeter of the figure.

4. A design has a series of trapezoids.

For each trapezoid, one parallel

side is always 1.5 m shorter

than the other parallel side.

The height of each trapezoid

is 6.0 m.

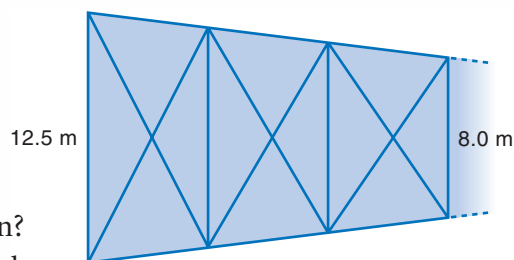

- What is the area of the 6th trapezoid in the design?
- How long is the design with 6 trapezoids?



The owners of a large shopping centre want to build a patio in front of the main entrance to attract more customers.

Your task is to design the tiled surface of the patio.

You must use tiles with these shapes: triangle, parallelogram, rectangle, trapezoid

The patio has the shape shown at the right. Each square on this plan has side length 10 cm.

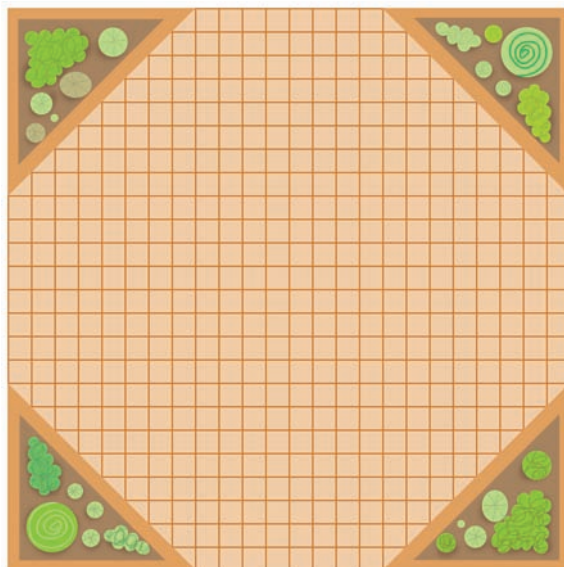

- You must include at least:
 - 3 triangles with different areas
 - 3 parallelograms with different areas
 - 3 rectangles with different areas
 - 3 trapezoids (that are not parallelograms) with different areas
- Use a formula to find the area of each tile.

Your teacher will give you a grid to draw your design.
Complete the design.

Colour the design if it helps to show the different figures.

Check List

Your work should show:

- ✓ the area of each different figure you used
- ✓ the formulas you used to calculate the areas
- ✓ a diagram of your design on grid paper
- ✓ an explanation of how you created the design



Reflect on the Unit

What do you need to know to find the area of a parallelogram, a triangle, and a trapezoid? Explain.

Include a diagram and an example to show how you found each area.